

Quick Installation Guide

ASW6K-UT-G3/ASW8K-UT-G3/ASW10K-UT-G3/
ASW12K-UT-G3/ASW15K-UT-G3

IV. Inverter's mounting

1. Use a $\Phi 10\text{mm}$ bit to drill 3 holes at a depth of about 70mm according to the location of the wall mounting bracket. (Figure A)
2. Insert three wall plugs into the wall and fix the mounting bracket to the wall by inserting three Screws (SW10). (Figure B)
3. Hang the slot on the back of the inverter to the hook on the top of the mounting bracket. (Figure C)
4. Secure the inverter to the mounting bracket on both sides using two M5 screws. Screwdriver type: PH2, torque: 2.5Nm. (Figure D)

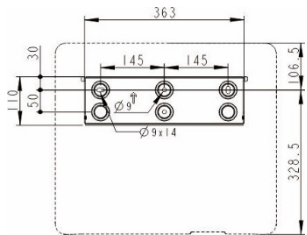

Figure A

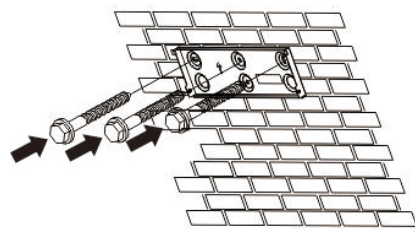

Figure B

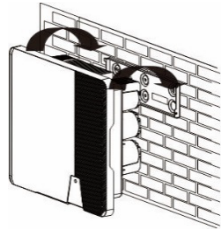

Figure C

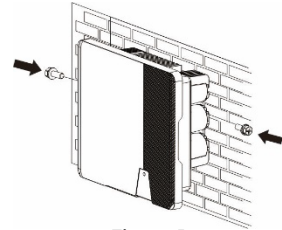

Figure D

V. AC connection



- All electrical installations must be done in accordance with all local and national rules.
- Ensure that all DC switches and AC circuit breakers have been disconnected and all power sources have been electrically isolated before any electrical terminations have been made. High voltages produced by the inverter may lead to electrical shock.
- In accordance with safety regulations, the inverter needs to be correctly grounded. When a poor ground connection (PE) occurs, the inverter will report PE grounding error. Please check and ensure that the inverter is grounded firmly or contact AISWEI service.

1. Strip the AC cable as shown in the figure and crimp the copper wire to the appropriate OT terminal (according to DIN 46228-4, provided by the customer).

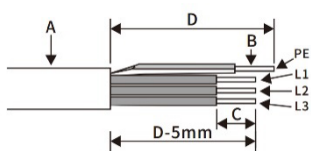

Object	Description	Value
A	External diameter	18-21mm
B	Copper conductor cross-section	4-16mm ²
C	Stripping length of the insulated conductors	12mm
D	Stripping length of the cable outer sheath	75mm

Note: the PE conductor is at least 5mm longer than the L conductors.

I. Safety Instruction

1. The contents of this document may be updated due to product upgrades or other reasons. Unless otherwise specified, this document only works as guide. All statements, information and suggestions in this document do not constitute any guarantee.
2. This product can only be installed, commissioned, operated and maintained by technicians who have carefully read and fully understood the user manual.
3. This product must only be connected with PV modules of protection class II (in accordance with IEC 61730, application class A). PV modules with a high capacitance to ground must only be used if their capacity does not exceed 1 μF . Do not connect any sources of energy other than PV modules to the product.
4. When exposed to sunlight, the PV modules generate dangerous high DC voltages which is present in the DC cable conductors and live components. Touching live DC cable conductors and live components can result in lethal injuries due to electric shock.
5. All components must remain within their permitted operating ranges at all times.
6. The product complies with Electromagnetic compatibility 2014/30/EU, Low Voltage Directive 2014/35/EU and Radio Equipment Directive 2014/53/EU.

II. Mounting environment

1. Ensure that the inverter is installed out of the reach of children.
2. To ensure best operating status and prolonged service life, the ambient temperature of the location should be $\leq 40^{\circ}\text{C}$.
3. To avoid direct sunlight, rain, snow, pooling of water on the inverter, it is suggested to mount the inverter in places which are shaded during the majority of the day or to install an external cover that provides shade for the inverter. Do not place a cover directly on top of the inverter.
4. The mounting condition must be suitable for the weight and size of the inverter. The inverter is suitable to be mounted on a solid wall that is vertical or tilted backwards (Max. 15°). It is not recommended to install the inverter on walls made of plasterboards or similar materials. The inverter may emit noise during operation.

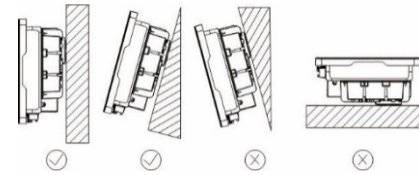
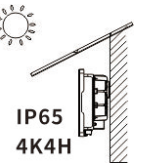

5. To ensure adequate heat dissipation, the recommended clearances between the inverter and other objects is shown in the image to the right:

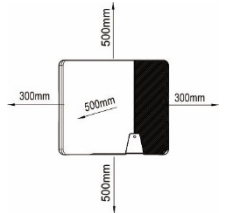

III. Scope of delivery

Inverter x1	Wall mounting bracket x1	DC connector 6K: 2+2 8K: 3+3 10-15K: 4+4	AC connector x1	Documentation x1	Screw accessory x1	Ai-dongle x1	RS485 Communication client x2

2. Insert the PE conductor, N conductor and L conductors (L1, L2 and L3) into the OT terminal, insert them into the corresponding terminals of the AC connector in the order as shown by the following arrows, and tighten the screws with the supplied hex key with a suggested torque of 2.0 Nm.

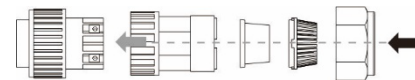

3. Secure the terminal block with a plastic clamp, screw the threaded sleeve body onto the AC connector, and tighten threaded nut.

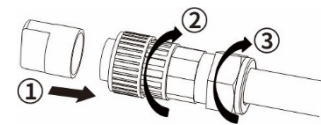

4. Insert the AC connector into the output terminal of the AC connector corresponding to the inverter and turn clockwise to tighten.

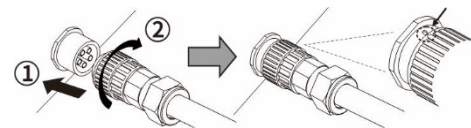

5. If required, you can connect a second protective conductor as equipotential bonding.

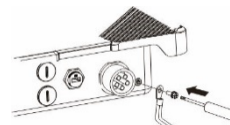

Object	Description
M5 screw	Screwdriver type: PH2, torque: 2.5Nm
OT terminal lug	Customer provided, type: M5
Grounding cable	Copper conductor cross-section: 4-16mm ²

VI. DC connection



- Make sure PV modules have good insulation against ground.
- On the coldest day based on statistical records, the Max. open-circuit voltage of the PV modules must not exceed the Max. input voltage of the inverter.
- Check the polarity of DC cables.
- Ensure that DC switch has been disconnected.
- Do not disconnect DC connectors under load.

1. Please refer to "DC Connector Installation Guide".
2. Before DC connection, insert the DC plug connectors with sealing plugs into DC input connectors of the inverter to ensure protection degree.

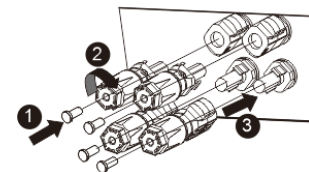

VII. Communication setup



DANGER

- Separate communication cables from power cables and serious interference sources.
- The communication cables must be CAT-5E or higher-level shield cables. Pin assignment complies with EIA/TIA 568B standard. For outdoor use, the communication cables must be UV-resistant. The total length of communication cable cannot exceed 1000m.
- If only one communication cable is connected, insert a sealing plug into the unused hole of sealing ring of the cable gland.
- Before connecting communication cables, ensure the protective film or communication plate attached to the

1. COM1&COM2: RS485

- 1) RS485 cable pin assignment as below, strip the wire as shown in the figure, and crimp the copper wire to the appropriate OT terminal (according to DIN 46228-4, provided by the customer)

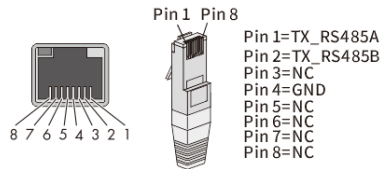

- 2) Unscrew the communication port cover cap in the following arrow sequence and insert the network cable into the RS485 communication client attached.

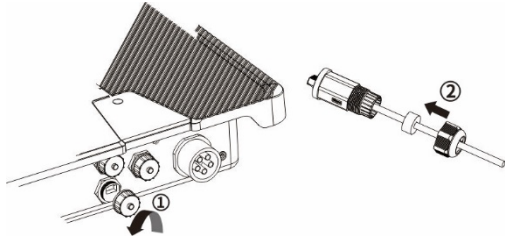

- 3) Insert the network cable into the corresponding communication terminal of the machine according to the arrow sequence, tighten the thread sleeve, and then tighten the forcing nut at the tail.

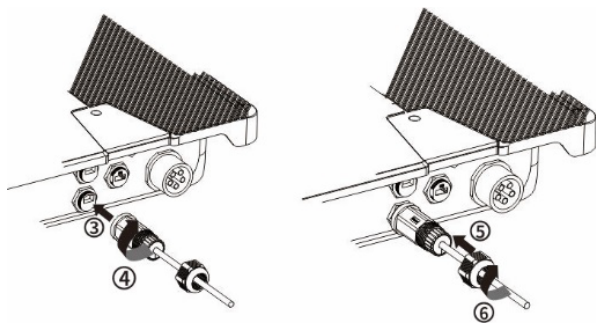

4

2. COM3: Ai-dongle

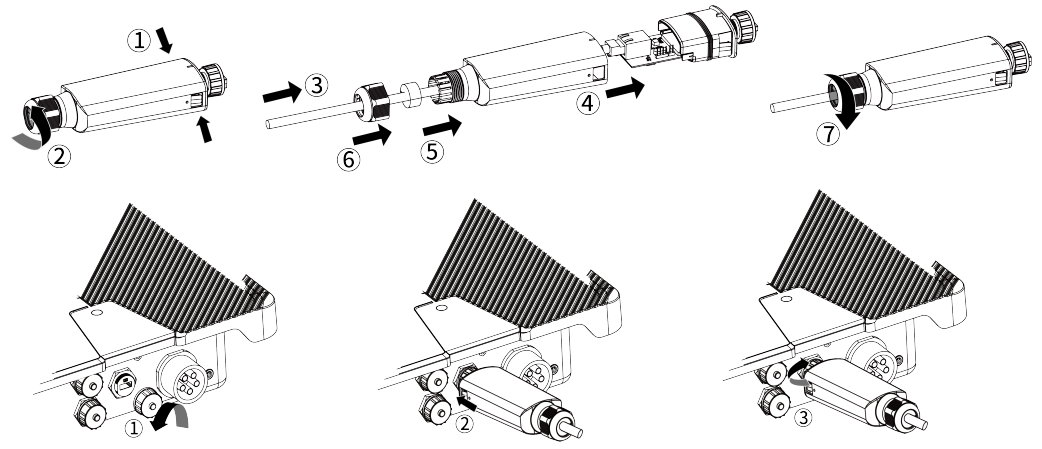

Notice



- Only applicable to the company's products, can't be connected to other USB devices.
- The connection refers to "Ai-dongle User Manual".

VIII. Commissioning



Notice

- Check that the inverter is grounded reliably.
- Check that the ventilation condition surrounding the inverter is good.
- Check that the grid voltage at the point of connection of the inverter is within the permitted range.
- Check that the sealing plugs in DC connectors and the communication cable gland are sealed tightly.

1. Switch on AC circuit breaker between the inverter and the grid.
2. Switch on DC switch.
3. Please refer to the AiProfessional/Aiswei App manual for commissioning of the inverter via Wifi.
4. When there is sufficient DC power and the grid conditions are met, the inverter will start to operate automatically.

IX. EU Declaration of Conformity

Within the scope of the EU directives:

- Electromagnetic compatibility 2014/30/EU (L 96/79-106 , March 29, 2014)(EMC)
- Low voltage directive 2014/35/EU (L 96/357-374 , March 29, 2014)(LVD)
- Radio equipment directive 2014/53/EU (L 153/62-106 , May 22, 2014)(RED)



AISWEI Technology Co., Ltd. confirms herewith that the inverters mentioned in this document are in compliance with the fundamental requirements and other relevant provisions of the above mentioned directives. The entire EU Declaration of Conformity can be found at www.solplanet.net.

5

X. Contact

If you have any technical problems with our products, please contact our service.

Provide the following information to assist in providing you with the necessary assistance:

- Inverter device type
- Inverter serial number
- Type and number of connected PV modules
- Error code
- Mounting location
- Warranty card

EMEA

Service email: service.EMEA@solplanet.net

APAC

Service email: service.APAC@solplanet.net

LATAM

Service email: service.LATAM@solplanet.net

AISWEI Technology Co., Ltd

Hotline: +86 400 801 9996

Add.: Room 904 - 905, No. 757 Mengzi Road, Huangpu District, Shanghai 200023

<https://solplanet.net/contact-us/>

Scan QR code:



Android

Scan QR code:



iOS



6